

DESIGN AND ANALYSIS OF STORAGE PRESSURE VESSEL

¹Shilpa P. Gole, ²Subim N. Khan

¹P.G. Student, Department of Mechanical Engineering, JSPM, Pune, (India)

²Associate Professor, Department of Mechanical Engineering, RSCOE (JSPM), Pune, (India)

ABSTRACT

Pressure vessels are probably one of the most widespread equipment within the different industrial sectors. For many years an ISO committee (ISO TC/11, Annaratone, 2007) was dedicated to study pressure vessels and provide design guidelines with necessary codes and design procedure of pressure vessel as per ASME sec VIII Div-1 to adequately cover the intended subject matter. Our object to do just basic valve design so we following all design criteria as per ASME codes. Application of the vessel is Buffer valve, Pressure relief valve, Balancing valve, pressure control valve etc However, even when the code includes specific regulations to determine the thickness of the different components, and taking minimum thickness it will leads to make thinning vessel with required factor of safety at design temperature and pressure With minimum thickness of the shell we can make light weight vessel and low cost vessel. At the same time it may operate at safe conditions facing some issues related to structural analysis. In this project first we design a CATIA based model will be created using this information using suitable mechanical parts design software like Catia/Ansys .A Finite element analysis is carried out on this model. Then a various testing under load and dynamic condition will be tested using analysis software like ANSYS.

Keywords- Pressure Vessel, ASME Code, Strain Gauge, Rectangular Rosette

I INTRODUCTION

Pressure vessels store energy and as such, have inbuilt safety risks. Many stages began to enact rules and regulations regarding the construction of pressure vessels. The several catastrophic accidents that occurred at the turn of the twentieth century that resulted in large loss of life. By 1911 it was noticeable to manufacturers and users of boilers and pressure vessels that the lack of promptness in these regulations between states made it difficult to constructs the vessels for interstates commerce. A group of these interested parties appeals to the council of the American Society of Mechanical Engineers to assist in the formulation of standard specifications for steam boilers and pressure vessels. After years of development the first Code rules for pressure vessels, entitled Rules for the construction of unfired pressure vessels in 1925. The ASME Pressure Vessel Code, in Par. UG-125, states that all pressure vessels

must be provided with a means of overpressure protection. In process industry, a process is continuously, further optimized to operate more efficiently closer to its mechanical limits such as its maximum allowable operating pressure. Besides the organizational and process control measures to maintain safe plant operation, the last stage of protection of a process apparatus against excess pressure is often through the use of a mechanical pressure safety release valve a piece of equipment. An important responsibility of a chemical plant designer is to make sure that a plant under design can be operated safely, it is provided with primary, secondary safety arrangement. One of the unsafe situations that can be arise during operation inability of a system to a pressure higher than that for which it was designed with help of sensor or actuator, in such circumstances we rely on mechanical system. [2] The region for increase/exceed inside pressure of pressure vessels are by filter tube clogging (instrument failure), maloperation, external fire, thermal expansion or some other regions. If the system is not protected, the excess pressure may be lead to failure causing mechanical indemnity, loss of costly material, emission of toxic chemical and maybe loss of life. Therefore Emergency shut off valve systems are wanted to protect personnel and equipment from the unwanted consequences of excess pressure. This our pressure vessel is design for valve so we can do the basic vessel design considering the, shell, flange, shell thickness, RF pad is not needed for basics valve design. our object to do just basic valve design so we following all design criteria as per ASME codes. Application of the vessel is Buffer valve, Pressure relief valve, Balancing valve, pressure control valve etc.

If enough strain gages are mounted adjacent to or overlapping each other to obtain the principle strains in an area, the resulting configuration is termed as strain rosette. The most common rosettes available commercially are of two types: one uses gages oriented at 0, 45, and 90° and is called rectangular rosette: the other at 0,60,120°, is called the delta rosette. Rectangular rosette has advantages such as short gage length, non-contacting, thermal resistant, measuring both in-plane strains and out-of-plane deformations' slopes simultaneously. Besides the advantages described above, the rectangular rosette has the advantage for measuring strains/slopes directly in two orthogonal directions. This avoids the strain transformation process which was generally required by the delta rosette. Also, since the rectangular rosette measures strains directly along the two objective directions instead of measuring in the direction with an angle, higher sensitivity will be achieved.

1.1 Objectives of Project

- a. Design of Pressure vessel. Our object to do just basic valve design. Application of the vessel is Buffer valve, Pressure relief valve, Balancing valve, pressure control valve etc
- b. Finding out strain in pressure vessel. (Analysis Method)
- c. Finding out strain in pressure vessel with rectangularrosette.(Experimental Method)

II) LITERATURE REVIEW

Meiqiu LI [1] has shown that Visual Design System Development of Wellhead's High Pressure Valve. The article introduces the advantages and the application of the visual design, analyzes the tendency and shortage of product development about high pressure valve used in wellhead. Combining the visual design method with collaborative design idea, a visual design system is designed for high pressure valve used in wellhead, which includes three modules. The development process and function of the system is described in detail. Based on a great deal database and modularized collaborative design, basic geometric design, three-dimensional Modeling, virtual assembly and finite element analysis (FEA) on chief parts are finished successfully. Practice indicated that the visual design system was an effective measure to improve efficiency of design, meet the demand of the development of product serialization, and reduce the cycle of development of product, reduce the cost. Geometric Design illustrates the function of the visual system. In general, it consists of four parts: Design Content: gate valve, check valve, relief valve, throttles valve and globe valve.

jovalasit, A. Mancuso [2] This paper is concerned with the misalignment of gauges. Electrical resistance strain gauges are increasingly used for the determination of the strain field in composite components. The effect of the angular misalignment of a strain gauge rosette on the determination of the strains in a composite material is investigated in this paper. The theoretical analysis shows that the strain error along the principal material directions depends on the difference of principal strains, on the angular misalignment of the rosette and on the angle between the maximum principal strain and the fibre direction.

Mr.Nilesh Jadhav, Prof. Sunil Bhat[3] has described Pressure valves are critical components of any process equipment, especially while handling toxic or flammable materials. In such cases it is very critical that the pressure in the system is well regulated and there is minimum risk of system explosion or leak due to excessive pressure in storage vessel. They have focused on to design, and optimize a pressure vessel valve, which will incorporate a feedback loop from the storage vessel, and regulate the flow, and if need be close the flow based on the magnitude of pressure. The feedback loop and in general the operational features of the valve are mechanical in nature, conceptualized using a combination of spring stiffness, and sliding parameters. At the time of simulate such a process, they experienced FEA is an extremely convenient tool which has reduced both the design costs and times to deliver the product. They explains the strategies used in the design of the valve and results of the operational simulation in FEA.

Liang Wang, Keyu Li, Salahaddin Sanusei [4]

Interferometric strain/slope rosette technique is an optical technique based on laser interferometric. It has advantages such as short gage length, non-contacting, thermal resistant, measuring both in-plane strains and out-of-plane deformations' slopes simultaneously. Six-faced delta rosette has been always utilized. In this paper, a new type of rosette, the eight-faced rectangular rosette was first applied. Besides the advantages described above, the new rosette has the advantage for measuring strains/slopes directly in two orthogonal directions. This avoids the strain transformation process which was generally required by the delta rosette.

Morrish Kumar¹ Shankar Kumar Moulick² [5]

Analysed Cylindrical or spherical pressure vessels (e.g. hydraulic cylinders, gun barrels, pipes, boilers and tanks) are commonly used in industry to carry both liquids and gases under pressure. When the pressure vessels is exposed to this pressure, the material comprising the vessel is subjected to pressure loading, and hence stresses, from all directions. The normal stresses resulting from this pressure are functions of the radius of the element under consideration, the shape of the pressure vessel (i.e., open ended cylinders, closed end cylinders, or sphere) as well as the applied pressure. A cylindrical pressure with wall thickness t , and inner radius r , is considered. A gauge pressure p , exists within the vessel by the working fluid (gas or liquid) Pressure vessels encountered in nuclear, aerospace and other structures are rotationally symmetric shells subjected to internal pressure. In the design of large rocket motor cases, the number of individual welded segments (viz., head end segment, nozzle end segment, cylindrical segments) will be chosen based on the feasibility of propellant casting, hardware fabrication limits and ease of transportation / handling, etc. These segments may be connected to each other through the tongue and groove type of joints. End domes having central circular openings will be provided at the head end and nozzle end of the motor case. The cylindrical portion of the casing for this type of configuration will be stressed maximum under internal pressure and hence governs the design.

.Patrik Šarga*, Peter Senko, [6] analyzed the residual stresses are the stresses that exist in object in the absence of external loading. These stresses are generated by technological process or by previous loading. In principle all technological processes rolling, forming and thermal processing etc. generate in produced object residual stresses. There are a number of destructive and non-destructive methods, which are used for determination of residual stresses. One of them is hole- drilling method. This method is semi destructive and its principle is based on drilling of a small hole to the center of strain gage rosette. When the material removed by drilling, relieved strains are recorded by the strain gage rosette, from which we can calculate the direction and size of the principal stresses. Hole-drilling method is usable for homogenous and non-homogenous residual stresses Residual stresses deserve big attention. Usually they are undesirable, it is difficult to identify them and expensive to remove them. Their presence can be harmful in large components and supporting structures such as vehicles or components of nuclear reactors, stands production machinery, bridges etc. The severity of their occurrence associated with limited options for its measuring and removing points out that we must pay attention to them. In most cases, it is difficult to determine residual stresses analytically. For this reason, experimental methods for the determination of residual stress are still very important.

Shaik A .L. et al [7]In the past several years there have been significant changes to the American Society of Mechanical Engineers (ASME) Boiler and Pressure Vessel (B&PV) Code and the use of international pressure vessel codes such as EN13445. This paper discusses some of the potential unintended consequences related to Governing Thickness of shell as per ASME. Here have a scope to change the code values by take the minimum governing thickness of pressure vessel shell to the desired requirements and also relocate of nozzle location to minimize the stresses in the shell. A low value of the factor of safety results in economy of material this will lead to

thinner and more flexible and economical vessels. Here we evaluated the stress in the vessel by Zick analysis approach.

K.T.Lau et al [8]:The ASME Code design criteria consist of basic rules specifying the design method, design loads, allowable stress, acceptable materials, fabrication, testing, certification and inspection requirements. The design method known as design by rule uses design pressure, allowable stress and a design formula compatible with the geometry to calculate the minimum required thickness of pressurized tanks, vessels and pipes. The ASME - American Society of Mechanical Engineers International Boiler and Pressure Vessel Code is made of 12 sections and contains over 15 divisions and subsections

III) DESIGN VALIDATION USING FEA

The structural model to be analyzed is divided into many small pieces of simple shape called elements. Finite Element Analysis (FEA) program writes the equation governing the behaviour of each element taking into consideration its connectivity to other element through nodes. These equations relate the unknowns.

3.1 Analysis

In analysis 01 we applied the pressure (0.3 Mpa) and fixed support as well as displacement.

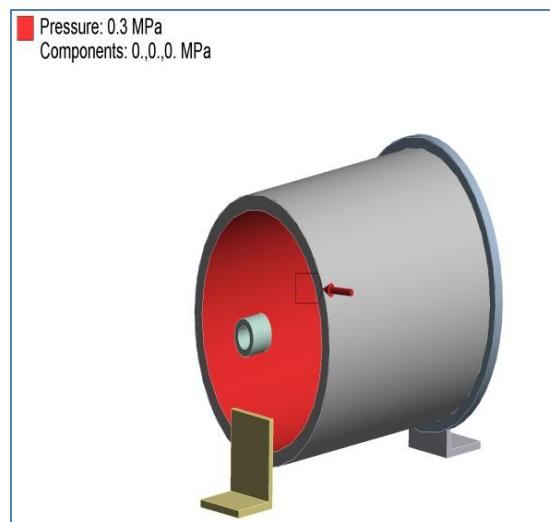

Figure (1) the internal pressure applied on the shell (0.3 Mpa)

Results

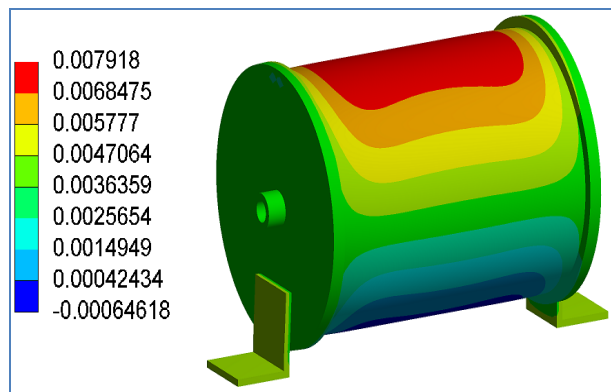

Figure shows deformation (Strain in E1) in 0.0079 mm.

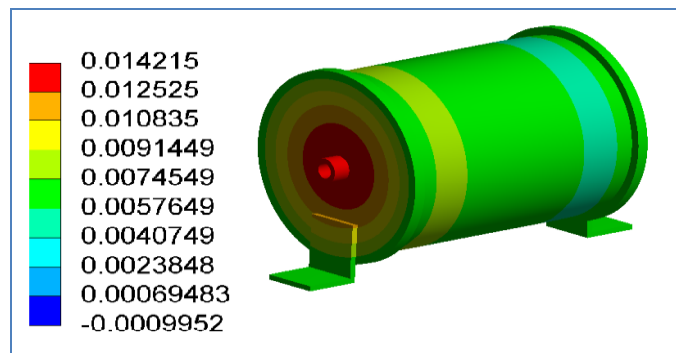

Figure (3) deformation (Strain in E2) in 0.00142 mm.

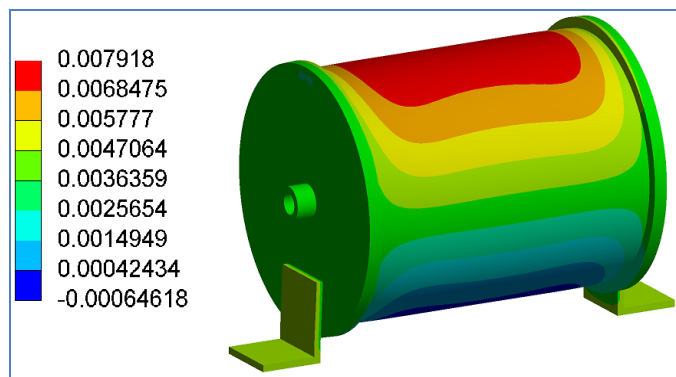

Figure (4) deformation (Strain in E3) in 0.0079 mm.

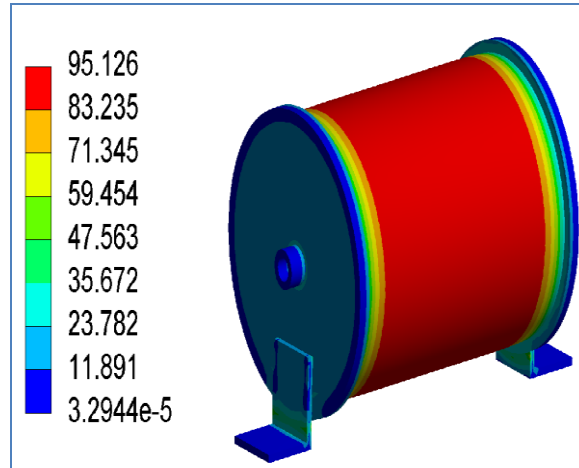

Figure Von mises stress in 95.126 Mpa.

Result table for analysis

Pressure in Mpa	E1 In mm	E2 In mm	E3 In mm	Allowable deformation in mm	Von mises Stress in Mpa	Allowable Stress in Mpa
0.3	0.0079	0.0014	0.0079	0.38	95.126	138

After completing the analysis 0.1 at Pressure 0.3Mpa and self weight we getting the above safe result.

Allowable deformation =350/length of the vessel in (133 mm)=0.38mm

Allowable stress is given by 138 as per ASME code. =138 Mpa

IV.EXPERIMENTAL PROCEDURE

Experimental procedure for vessel test-

As per completed the design part and analysis part we are performed the actual model with experimental setup. Test was perform by using rosette strain gauge. following image shows the while performing the test.

Introduction

Resistance of a wire of length ‘L’ and cross sectional area ‘A’ is given by equation $R = \delta * L / A$, where δ is resistivity of wire material. If such a wire is subjected to strain its resistance will change depending upon change in L and A. In strain gauge technique a very thin wire of the order of 5 to 10 micron diameter is pasted on metal part by means of suitable adhesive. The metal part then subjected to load, which finally results induction of strain in it.By knowing

the strain values, stress values are calculated by using standard strength of material relations. Hence the values of stresses at various points of interest can be found out experimentally, resulting into complete stress picture of the metal part under investigation. Installation of strain gauge

Following steps are followed while the strain gauges installations:

- First of all the base resistance of the unstrained strain gage is measured after its proper mounting but before complete wiring.
- Surface contamination is checked by measuring the isolation resistance between the gauge grid and the stressed force detector specimen by means of an ohmmeter.
- Irrelevant induced voltages in the circuit are checked by reading the voltage when the power supply to the bridge is disconnected. It ensures that Bridge output voltage readings for each strain-gage channel are practically zero.
- Then excitation power supply is connected to the bridge and both the correct voltage level and its stability are verified.
- Strain gauge bond is tested by applying the pressure to the gauge and it was found that the reading was unaffected.[23]

After mounting the strain gauge on the rods it was connected to the Wheatstone bridge and the change in strain is easily calculated by change in resistance in foils. For the different temperatures of the absorber tank strain on each rod is measured and it is found that the stain value is in the acceptable limit which does not cause any buckling failure in the rods.

4.1 Investigation Procedure

For investigating the stresses in the metal part the entire cases can be categorized in two groups –

- a) When direction of stresses is known.
 - b) When direction of stresses is unknown.
- a) In first case it is easy to analyze because the direction in which the maximum principle stress occurs is known in certain metal parts, such as beams, direct tension or torque cases. In such cases strain gauges can be oriented in already known direction and single element strain gauges serve the purpose.
 - b) Second case can be treated as generalized case and following exhaustive steps are to be followed in such cases –
Out of entire machine part under investigation, critical areas to be decided by the investigator. To decide these critical areas one should study the failure history, nature of loading, nature of fixing boundary conditions etc. related to part under investigation.

The total numbers of strain gauges, which are to be pasted at various points on the surface of the part, are to be decided. Here it should be noted that, strain gauges can measure only surface strains and not strain at interior of cross section.

Single element strain gauges will not serve purpose; hence three elements rectangular type gauge is used.

By using proper adhesive and following proper procedure gauges are fixed at various points of interest.

a) Strain gauge installation is checked by multi-meter.

b) Using multi-channel strain indicator, connection of gauges are done.

Without loading the machine part initial balancing of all gauges is done on strain indicator.

By applying rated pressure on cylinder micro strain values of each gauge are recorded.

The experimental set up consists of a cylinder which can be pressurized by air using foot pump. The pressure can be measured with help of Pressure Gauge mounted on Foot pump

4.2 Calculations

If the strain values are desired, then following equation is used

$$E_{max} = \frac{1}{2}(E_1 + E_3) + \frac{1}{2}\sqrt{\{(E_1 - E_3)^2 + [2E_2 - (E_1 + E_3)]^2\}}$$

$$E_{min} = \frac{1}{2}(E_1 + E_3) - \frac{1}{2}\sqrt{\{(E_1 - E_3)^2 + [2E_2 - (E_1 + E_3)]^2\}}$$

Where, E max and E min are principal strains.

Angle made by 'Principal strain' with X direction is given by,

$$\tan 2\theta = \frac{2E_2 - (E_1 + E_3)}{E_1 - E_3}$$

θ = The angle made by principal stress & principal stress direction.

Experimental Strain Values For Sample Calculation.

Sr no.	Pressure in Mpa	Strain in mm X,E1	Strain in mm Y,E2	Strain in mm Z,E3	Angle θ
1	0.30	0.008	0.015	0.008	0.85

V EXPERIMENTAL VALIDATION

Simulation (Deformation Value) strain values for sample calculation

Sr no	Pressure in Mpa	Strain in mm X,E1	Strain in mm Y,E2	Strain in mm Z,E3	Angle θ
1	0.30	0.00793	0.0148	0.00793	0.45
2	0.40	0.0130	0.0234	0.013	1.33
3	0.50	0.0159	0.0279	0.0159	1.59

Experimental result for sample calculation

Sr no.	Pressure in Mpa	Strain in mm X,E1	Strain in mm Y,E2	Strain in mm Z,E3	Angle θ
1	0.30	0.008	0.015	0.008	0.85
2	0.40	0.013	0.023	0.013	1.31
3	0.50	0.016	0.028	0.016	1.60

VI CONCLUSION

The outputs obtained from structural analysis are stress and deformation. From safe structural design point of view it is necessary that the stress induced in structure must be less than permissible or design stress. In all parts, the actual stress is less than design stress, so the Pressure vessel is safe from structural point of view. As we performing the experimental, test we get the deformation result and they are compare with the simulation result the, difference between them are less than 5% so this result are acceptable.

REFERENCES

[1] Doc. Ing. Vladimír Ivančo, (June 2011) “Nonlinear Finite Element Analysis”PhD. Faculty of Mechanical Engineering, Technical University of Košice, Slovakia HS Wismar.

[2] “Fundamental FEA Concepts and Applications”. A Guidebook for the Use and Applicability of Workbench Simulation Tools from ANSYS, Inc.

[3] Neville F. Rieger. “The Relationship between Finite Element Analysis and Modal Analysis”. Stress Technology Incorporated, Rochester, New York, Page 1-3.

[4] Kelly,” Solid Mechanics part I”. Thin walled pressure vessel theory, Section 4.5,Page 127,131.

[5] R. B. Agarwal,” Introduction to Finite Element Analysis”. Page 1-5

- [6] Brian Vicich; Craig Ryan; Kevin Meredith,(2007) "Linear vs. Non-Linear Contact Analysis". Page 9.
- [7] R. B. Patil, (2007),"A text Book of CAD/CAM & Automation". Page 148-149.
- [8] J. Ed Akin, (2009), "Finite Element Analysis Concepts via Solid Works". Rice University, Houston, Texas, page 204-205.

Hand Books

- [9] ASME Section VIII, Division 1
- [10] ASME Section VIII, Division 2
- [11] ASME Section II, Part-D

