

# DESIGN AND DEVELOPMENT OF PUNCHING DIE & FEEDER MECHANISM

Ravindra Laxman Gaikwad<sup>1</sup>, Bhagyashri Ramesh Ahire<sup>2</sup>,

Amol Kailas Dhurjad<sup>3</sup>, Vishal Rohidas Shinde<sup>4</sup>

Yuvraj Suresh Khadke<sup>5</sup>

<sup>12345</sup>Matoshri College of Engg & Research Centre,

Nashik, Maharashtra, (India)

## ABSTRACT

Today in the rapid competition of the industries to get the best quality of the product in the minimum required time is the main aim of industries. To get the best quality and maximum production most advanced machines are used. But there are no facts that use only the advanced machines, to maintain their performance is real requirement of the industries, also to give proper facilities to the workers with good environmental condition and to reduce their efforts is one of the objects to achieve the best quality and high production.

So we have done design and development in existing punching die with a new die which having more production capacity as per requirement to meet production value and also design feeder mechanism for effective product handling and ease of working to the operator.

**Keywords:** 3-D Modeling, Feeder Mechanism, Punch & Die, Punching Productivity

## I. INTRODUCTION

The press is a metal forming machine tool, designed to shape or cut metal by applying mechanical force or pressure with help of press tool. The metal is formed to desired shape without removal of chips. Press tools are exclusively intended for mass production work. Sheet metal operation plays an important role in engineering works. Press tool are made to produce a particular component in very large numbers, mainly out of sheet metal. The principle press tool operations are cutting and forming operations of sheet metal. Sheet metal components such as automobile parts, parts of house hold appliances and electronic equipment's are produced by press tools.[1] Nowadays lot of sheet metals parts are being utilized in lot of sectors irrespective of particular fields like mechanical, electrical, electronics, computers. Sheet metal components are mainly used for the followings

- Lesser in weight
- Less Expensive
- Replaceable and better aesthetics

### 1.1 Problem Statement

- To design for die and punch which are highly efficient.

- To develop a punching die along with its feeder to improve production rate of product by minimizing human efforts and machining time.
- Design and simulate of die and punch for metal rod on round bending.

## 1.2 Scope

The objective of this project is to develop an assistive technology device that will enable individuals with severe disabilities to excel in the workplace. This will be done by identifying and understanding a process where a need for improvement exists and designing a device in that manner. [3]

For the main purpose of this research, the following scopes are created:

- Improving productivity, job performance and reducing the process time.
- Develop the most efficient and simple design of the punch and die so that they are easy to manufacture; complex shape and sizes are not recommended.
- The next scope is geometry measurement which involves the dimensions of a design including the length, width, thickness, height, angle between lines, diameter etc. The dimensions of the design of the die and punch are measured to form a .3-D view to get clearer picture.
- Perform analysis by F.E.A and validation. Validation is the process of checking if something satisfies a certain criterion. Validation is important because it disallows data that cannot possibly be either true or real to be entered into a database or computer system.

Develop the methodology of the proposed design.

## II. IMPORTANT CONSIDERATIONS FOR DESIGN OF A DIE SET

- Cost of manufacturing depends on the life of die set, so selection of material should be done carefully keeping strength and wear resistant properties in mind.
- Die is normally hardened by heat treatment so design should accommodate all precautions and allowances to overcome the ill effects of heat treatment.
- Accuracy of production done by a die set directly depends on the accuracy of die set components. Design should be focused on maintaining accurate dimensions and tight tolerances.
- The process should be shock proof, if it is unavoidable, shock resistant properties should also be considered while selecting the material of components of die set.
- Along with the important design consideration one should also know about the proper material selection for components of a die set various types of tool steels with their suitability for components of die set.
- Material or selected tool steel should be very hard to resist wear and strong to bear load to the same time die set components may have very complicated shape, design and need very accurate sizing. Most of them are manufactured by machining and finishing operations. Their manufacturing involves processing of tool steel to make these components, and then these are hardened by different hardening methods like water hardening, oil hardening, air hardening and hard coatings while selecting a die set component material following factors should be taken in care.
- Life of the die set component as required.

- Ability to bear wear, shock and load (type of process subjected).
- Their costs, both initial cost and operating costs.[2][3]

### **III. IMPORTANCE OF SPRINGBACK EFFECT**

The evaluation of forming performance is a great necessity when large-sized complex parts like automobile panels are press formed to control the forming defects to get precise parts. Shape fixability is one of the main indices to assess sheet formability. Shape fixability is defined as the fixation degree of size and shape of the formed part. During bending, the load is applied to bend the part in the desired shape. After bending, when the load is removed, the total strain on the work part is reduced due to elastic recovery. This causes a shape discrepancy in the work part referred to as springback. The maintenance of geometric tolerances in the finished part is an important challenge in air bending process. This issue is related to spring back which is the outcome of the complex interaction of various parameters such as properties of the material, geometry of the part, tooling and process parameters. During bending, the bend force is the force needed to deform the sheet metal to the required shape. The bend force-punch travel relations can be compared with bending model results and necessary corrections can be made to achieve better in process control. [2]

### **IV. MATERIAL SELECTION**

#### **4.1 For Punch and Die [4]**

Material Selected: WPS

Steel Grade: Die steel D3/1.2080

Model Number: 1.2080/D3/Cr12

Technique: Cold Drawn

Annealed Hardness: 269-217 HBS

Special Properties:

- Good wear resistance and compressive strength
- Resistance to plastic deformation
- Good hardenability

#### **4.2 For Feeder Mechanism [4]**

Material Selected: Mild Steel

Model Number: 1.0401

Elongation: 10-14% Min

Technique: Cold drawn

Special Properties:

- High ultimate strength
- Low in cost
- Less wear and tear property

## V. BENDING CALCULATIONS

### 5.1 Nomenclature [5]

Tensile strength =  $F_t = 300 \text{ N/mm}^2$

Thickness =  $T = 5 \text{ mm}$

Width =  $W = 50 \text{ mm}$

Transverse Length =  $L = 27 \text{ mm}$

### 5.2 V-Bend Calculations [4][6]

a. Minimum inside radius (R) :

$$R = \frac{F_t}{320 * T} \quad R = 4.6875 \text{ mm}$$

b. Minimum Flange length (a):

$$a = \frac{W - T}{1.41} \quad a = 31.91 \text{ mm}$$

c. Elongation (e):

$$e = \frac{T}{2 * R} \quad e = 0.3478 \text{ mm}$$

### 5.3 Force Calculations [6]

a) V Bending force ( $V_{bv}$ ):

$$V_{bv} = \frac{1.33 * L * T_2 * F_t}{W} \quad V_{bv} = 538.6015 \text{ N}, V_{bv} = 0.5 \text{ ton}$$

b) Channel Bending Force ( $V_{bv}$ ): [6]

$$V_{bv} = \frac{2.66 * L * T_2 * F_t}{W} \quad V_{bv} = 1077.7 \text{ N}, V_{bv} = 1.09 \text{ tonnes}$$

### 5.4 Stress Calculations [6]

A. Compressive stress ( $\sigma_c$ ):

$$\sigma_c = \frac{F}{A} \quad \sigma_c = 27.43 \text{ N/mm}^2$$

**B. Bending stress ( $\sigma_b$ ):**

$$\sigma_b = \frac{F}{A} \qquad \sigma_b = 1.95 \text{ N/mm}^2$$

PARAMETERS	VALUE
Minimum inside radius	4.6875 mm
Minimum Flange length	31.9100 mm
Elongation	0.3478 mm
V Bending force (For 1)	0.5 tonne
Channel Bending Force (For 1)	1.9 tonnes
Compressive stress (For 1)	27.43 N/mm <sup>2</sup>
Bending stress (For 1)	1.95 N/mm <sup>2</sup>
V Bending force ( For 4)	2 tonnes
Channel Bending Force ( For 4)	7.6 tonnes
Compressive stress ( For 4)	109.7 N/mm <sup>2</sup>
Bending stress ( For 4)	7.8 N/mm <sup>2</sup>
Factor of Safety	12.5

**Table 5.4.1. Final output Parameters**

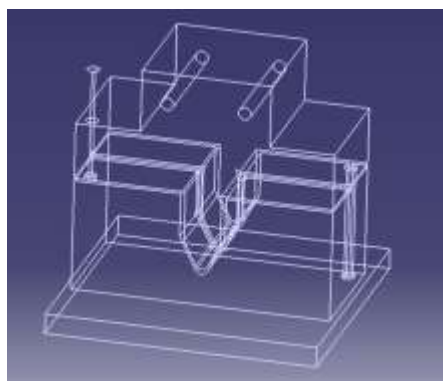

**Fig 5.4.1 3-D Model of existing Die and Punch Fig**



**5.4.2 Actual existing Die and Punch**

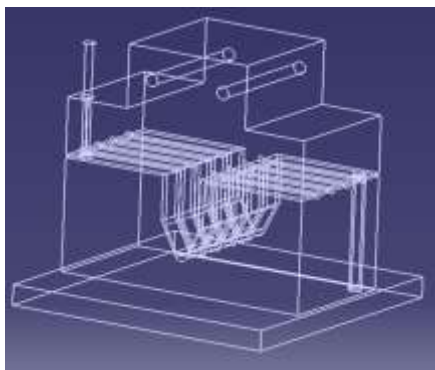

Fig 5.4.3 3-D Model of designed Die and Punch



Fig 5.4.4 New Die and Punch



Fig 5.4.5 Feeder Mechanism



Fig 5.4.6 Ejector Mechanism



Fig 5.4.7 Assembly of New Die, Punch, Feeder and Ejector mechanism

Sr. No.	Point of comparison	Existing	New
1	Capacity	One per stroke	Four per stroke
2	Product cost	Moderate	Very low
3	Running cost	Moderate	Very low

4	Product cycle	High	Very low
5	Maintenance	Moderate	Low
6	Space requirement	less	Moderate
7	Speed of cutting	Moderate	Very Low
8	Requirement of skilled operator	Yes	No
9	Rate of cutting	Moderate	Very Low
10	Complexity	High	Low
11	Power requirement	Moderate	Very Low

**Table 5.4.2 Comparison of Existing & New Die**

## VI. CONCLUSION

We developed a branch and bound approach which is coupled with quick, effective bounds to optimize the “Design & Development of Punching Die & Feeder “which serves the design of punching die and feeder for punching machine within manufacturing cell to improve various parameters of machine productivity.

As per our objectives which were to design new feeder system and to replace existing die with a new die to improve the production rate, to reduce the product cycle time and also to reduce defectives we taken care of all of it. We satisfactory completed our project by meeting all our objectives also we have tested all the output results by comparing it to our design outputs and done some post processing activities also to do some minor changes.

## REFERENCES

- [1] Iulian stanasel, florinblga and Iona redo, Research on parametric design of die punch. (IJRSM Mar 2012, Vol. 10, Issue 1)
- [2] VaditakeSukhadeoSatoba and Shinde Vilas B, An Overview of Effect of Punch Tool Wear Radius on Burr formation (IJMER, Jan2015, Vol. 6, Issue 1)
- [3] S. B. Tor, G. A. Britton and W. Y. Zhang, Functional Modeling in Conceptual Die Design.
- [4] Khurmi R. S. Gupta J.K., A textbook of machine design, first edition, S. Chand Publication, 1979.
- [5] Thomas Bevan, The Theory of Machines, Third edition, CBS publishers, 2005.
- [6] Bhandari V.B., Design of machine elements, eighteenth edition, MC Graw-hill companies,2003.
- [7] PSG design data, Coimbatore, first edition KalaikaikathirAchchagam, 2003.
- [8] JOSEPH V. WOODWORTH,Punches, dies and tools for manufacturing in presses,1941
- [9] Jeff Lantrip, John G. Nee, David Alkire Smith, Society of Manufacturing Engineers, Fundamentals of Tool Design, Fifth Edition,2003