

ENVIRONMENTAL MONITORING FOR IoT USING MULTITIERED & LOW POWER WSN

Sarika Shinde¹, Prof. Kanchan Pujari²

¹Student DPCOE Pune ME,VLSI & Embedded System, Pune University,(India)

² Professor Department of E & TC, DPCOE Pune(India)

ABSTRACT

Internet of things provides a connection of physical things to the internet & makes it possible to control any place from a distance by accessing remote sensor data.WSN is most recent & cost effective system for environmental monitoring applications. This paper deals with wireless sensor network based environmental monitoring internet of thing applications, controlling of sensors through ARM processor & transmission of data safely through RF. This system can be deployed in many applications like forest, agriculture, botanical research, industrial waste monitoring, or location can be any “thing” we may be interested in. Design of application is done by considering easy deployment, high number of sensors, low cost, low power, low maintenance, quality of service, safe communication & its long life.

Keywords : *IoT, GSM, RFID, Wireless Sensor Network, Sensor Nodes, GUI Node.*

I. INTRODUCTION

Embedded systems which can be called as smart objects are building block of “internet of things” & also connected to the internet. Two technologies mainly considered for the internet of thing concept: RFID technology & the wireless sensor network (WSN). The RFID technology which can be called as extension of ubiquitous optical bar code usually found on many products which needs an attachment of smart ID tag to a product for identification of product from a distance. [2] Wireless sensor network have gain worldwide attention because of its broad range of applications. The common vision of environmental monitoring system is associated with internet of things through the use of sensors.Among all the applications of IoT, earth monitoring receives lots of interest as environment monitoring is the need of today’s human life. It is very challenging to monitor open nature because of its difficult & harsh operating system. Also it is difficult to manage & maintain the physical access to the field for its deployment. Internet of things & WSN platform make easy to monitor environment especially in open nature because of its low cost, long unattended service , large number of nodes , low maintenance, ease of deployment.[1]

A. Outline of some relevant previous work

EMMON [3] project fielded 300+ nodes WSN system which is organized into Zigbee based cluster tree network model. Design approaches of EMMON architecture based on the simplicity, technical maturity, test-bed testing,

& modular designing. [3] The architecture is based on C & C (command & control) principle. It is also based on most widely used standard & COTS technologies for WSN, IEEE 802.15. Matlab OPNET is used for result simulation. A standards based wireless development environment [4] project uses open source implementation of fully standards based protocol stack i.e. IEEE 802.15.e time synchronized channel hopping standard coupled with internet of things. It uses 32 bit cortex-m architecture. The system is based on low power mesh network & this network is connected to PC (Internet). The system requires ultra low power which enabled a range of applications. Design & implementation of low power WSN for environmental monitoring [5] a project by Jue Yang based on four layer structure named as physical, logical, web presentation & user layer. A variety of sensors are used at a physical layer. At a server side data base SQL is used for monitoring the site or environment. Design of WSN platform for long term environmental monitoring for IoT applications [1] a project by Mihai T. Lazarescu uses sensor node & gateway node. Sensor nodes are used for field data acquisition using on board transducers, processing & transmit this to the gateway node using short range RF communication. Gateway node process, store and send this data to the server through long range communication channels. [1] The node microcontroller used is ATMEL AVR 1281 with 2 KB program and 128 bytes data memory.

II. PROPOSED SYSTEM

Flexibility in monitoring systems is essential to support variety of contexts such as river monitoring, intelligent agriculture applications, pollution detection, person or animal detection. [6] This project includes both indoor & outdoor applications. Though there are many inventions in monitoring systems of environment, most of the existing systems for monitoring are manual. They cannot cover larger distances. There are limitations for human to monitor all the parameters. This causes the chances of human errors. Like human calculations may not be precise sometimes or it may not be possible for human to cover larger area while monitoring. So here is necessity of smart system which will automatically measure the parameters. In this application parameter calculations and monitoring will be precise even over the larger area. Here wireless sensor network is built to monitor environmental conditions like : water level for lakes, rivers, sewages, streams; gas concentration in air for cities & laboratories; soil humidity; lighting conditions; landslide, position changes, person/animal detection etc.

• Platform Structure

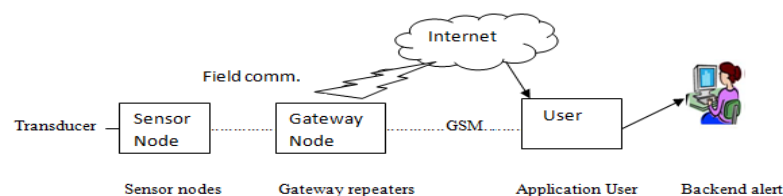

Fig. 1 Tiered structure of WSN platform

The tiered structure of WSN platform is shown in figure . Large number of sensor nodes can be spread within an area of interest to monitor dense temporal and spatial data by extending period of time which can enable researcher to analyze if there is any complex interactions within the environment.[7] Sensor nodes are equipped

with a short ranged radio to enable communication allowing them to pass there data to the gateway nodes for further process. Prime importance for such a systems is to minimize energy consumption since there is no human interaction for the desired operatonal periods for several years. Sensor nodes are used for field data acquisition using transducers, processing, and communication to gateways. GUI (Graphical user interface) node or receiver node can be a PC connected to a internet. GUI nodes are used to process, store and periodically send the field data to user using internet. GSM is also used for communicating over longer distances and to alert authorities via messages.

III. SYSTEM BLOCK DIAGRAM

Sensor node can be placed in the environment that to be monitor and monitoring unit will be in some office. Sensor node can be water level, CO, humidity, light intensity, landslide, person or animal detection etc. Water Level sensor is float type sensor which will check for river level and will give intimation if level crosses to danger level. CO sensor is MQ7 which is used to sense carbon monoxide gases in the environment. If there is any land sliding MEMs sensor ADXL335 will give intimation of it. To sense presence of water in the air humidity sensor DHT11 is used. For detection of person & animal PIR sensor is used.

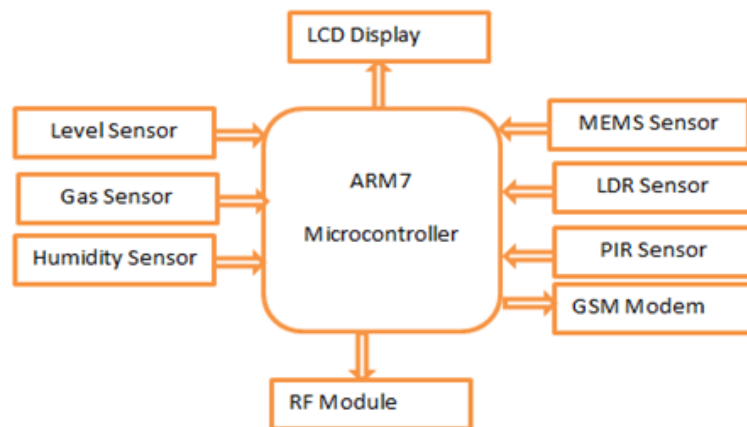

Fig.2 Block Diagram of transmitter

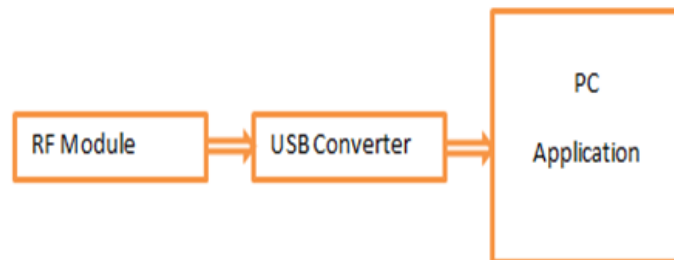

Fig.3 Block diagram of Receiver

Specification of sensor node is very important for good performance of application. Most important specification is its cost reduction, long maintenance free service, and simple deployment of system. [1] Considering all these parameters sensor nodes used in the project are very cheap & lifelong. These sensors are interfaced to ARM7 based Microcontroller LPC2138 which is heart of the system. Analog Sensors output is

analog so ADC is needed. ARM 7 has built in 2 ADCs, so these ADCs are used to convert analog output to digital. Also LPC2138 is having 32 bit RISC architecture so processes faster as compare to other Microcontrollers. [1] Digital sensors can connect directly to the processor. RF communication is preferred as it is trusty and noise free. Bluetooth is avoided as its having a limited range. GSM is also used for communicating over longer distances and to alert authorities. Main role of GUI node is to collect data, process, & forward it to internet connected server. Monitoring node will log all the data received from sensor node to the PC. GUI based PC application will show all the data in tabular forms. GUI will also have real time date and time so as to differentiate conditions on sensor node side. Wireless connectivity is given between these two nodes through RF communication. JAVA is used for GUI application Monitoring unit will have GSM which will be auto triggered as any of the condition becomes worse.

IV. SYSTEM SOFTWARE DESIGN

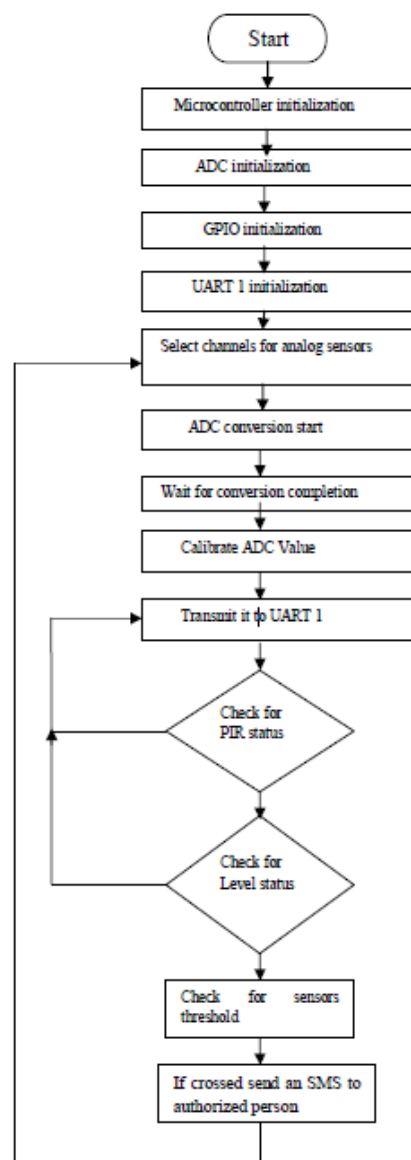

Fig. 4 Flowchart for proposed system

LPC 2138 uses WSN platform to support its application development. The Software controls digitally process of setting serial SPI interface between ARM 7 & UART1, ARM7 & UART2. [8] Sensors detect the required data which is transferred to the LPC 2138. As mentioned in the algorithm ADC should initialize for the analog sensors, which converts analog data into digital data. This digitized data is transferred to the UART 1. Two sensors PIR & Level sensor are digital so they can directly connected to the GPIO pins. Processor's GPIO pins are initialized for digital sensors. All sensors send the data to the processor. All sensed data is processed & under control of processor. It will check if threshold level crossed. If crossed then it goes again to step 6.

V. CURRENT HARDWARE IMPLEMENTATION

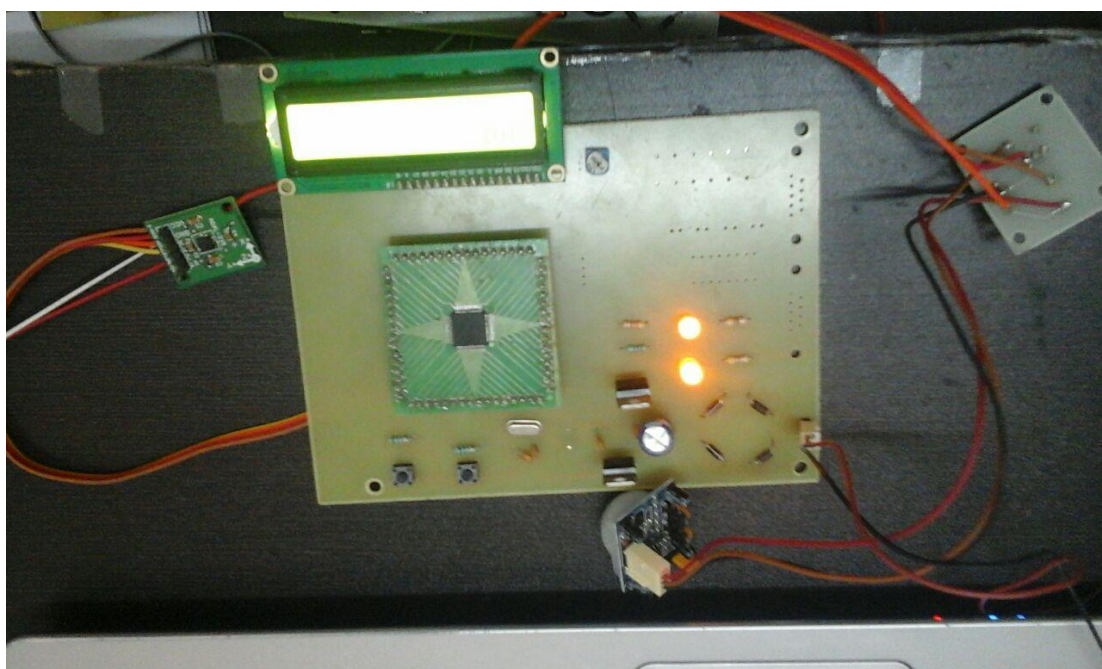

Fig. 5 Hardware implementation for MEMS sensor & PIR sensor

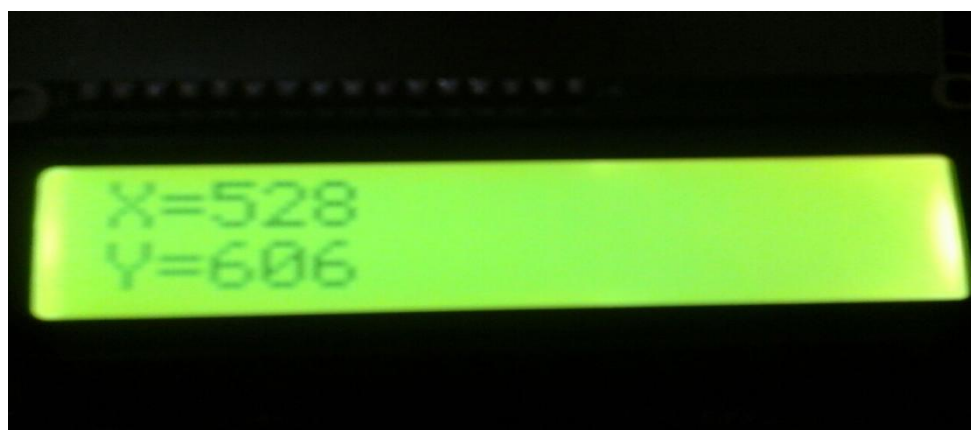

Fig. 6 Result of MEMS sensor

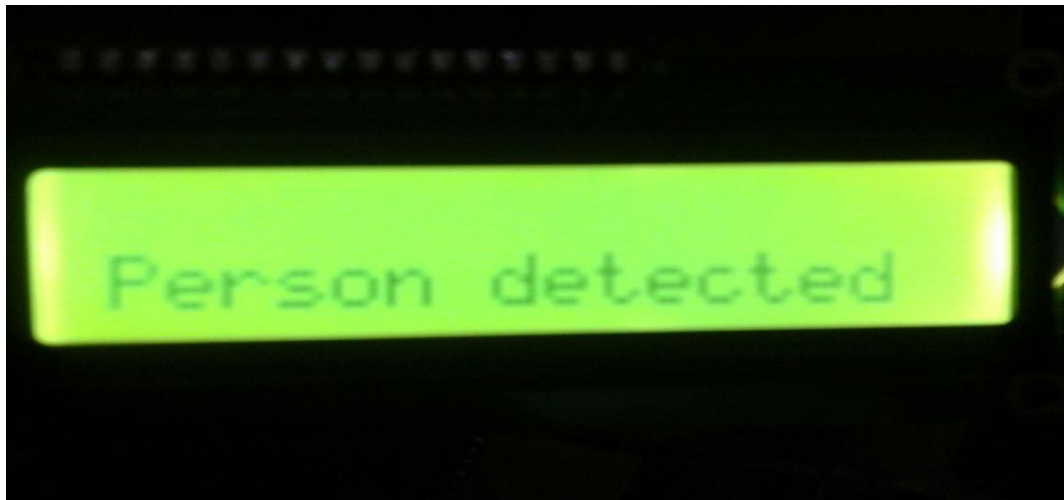

Fig.7 Result of PIR sensor

VI. BENEFITS

1. Wireless Sensor Systems.
2. Automatic Indication.
3. Accurate system.
4. No intervention of Humans so precise.

VII. LIMITATIONS

1. Sensor damage is not considered.
2. GSM can have range problem.
3. Parameters threshold can be change depend upon Environment.

VIII. APPLICATIONS

1. Environment Monitoring.
2. Agriculture.
3. Industrial waste monitoring.
4. Green Houses.
5. Botanical Research.

IX. CONCLUSION

Traditionally WSNs are considered as enablers for IoT concept. System is having wide variety of applications so very useful at a very low cost. Sensor damage can be possible but it is not considered. WSN platform is considered from all the aspects like simplicity, flexibility, reusability, sensors fully optimization, gateway nodes, and communication protocol. Parameters threshold can be changed depending upon the environment.

REFERENCES

- [1] Mihai T. Lazarescu “Design of a WSN Platform for Long-Term Environmental Monitoring for IoT Applications”
- [2] Scholarly articles by Internet of things, Kopetz
- [3] S. Tennina, M. Bourroche, P. Braga, R. Gomes, M. Alves, F. Mirza, V. Ciriello, G. Carrozza, P. Oliveira, and V. Cahill, “EMMON: A WSN system architecture for large scale and dense real-time embedded monitoring,” in *Embedded Ubiquitous Comput.*, Oct. 2011, pp. 150–157.
- [4] T. Watteyne, X. Vilajosana, B. Kerkez, F. Chraim, K. Weekly, Q. Wang, S. Glaser, and K. Pister, “OpenWSN: A standards-based low-power wireless development environment,” *Trans. Emerg. Telecommun. Technol.*, vol. 23, no. 5, pp. 480–493, 2012.
- [5] J. Yang and X. Li, “Design and implementation of low-power wireless sensor networks for environmental monitoring,” *Wireless Commun., Netw. Inf. Security*, pp. 593–597, Jun. 2010.
- [6] M. Corra, L. Zuech, C. Torghele, P. Pivato, D. Macii, and D. Petri, “WSNAP: A flexible platform for wireless sensor networks data collection and management,” in *Environ., Energy, Struct. Monitor. Syst.*, Sep. 2009, pp. 1–7.
- [7] Pascal Von Rickenbach “Energy-Efficient Data Gathering in Sensor Networks”
- [8] Margaret Richardson Ansah, Yan Shu, Cao Qing Hua “High Temperature Wireless Sensor Network Monitoring System for Coalmine Fire “ in *IOSR Volume 9, Issue 3, Ver. V (May - Jun. 2014), PP 73-78*