

## DESIGN OF GO-KART VEHICLE SYSTEMS

Ravindra Laxman Gaikwad<sup>1</sup>, Prathmesh Vishwas Waghmare<sup>2</sup>,

Lalit Daulatrao Deore<sup>3</sup>, Akshay Mukesh Mutake<sup>4</sup>

<sup>1234</sup>Matoshri College of Engg & Research Centre, Nashik, Maharashtra, (India)

### ABSTRACT

*This paper gives description of the design considerations, dynamic analysis of various systems and mathematical data which are involved in the design of a Go-Kart vehicle. Vehiclesystems should meet international standards and is also cost effective at the same time without compromising performance. The main focus has been given on the simple design procedure for high performance, easy maintenance, driver ergonomics and safety at very reasonable price. Also we have focused on every single system to improve the performance of each component without comprising the final set parameters. This study aims to design and develop of roll cage and other limiting specifications for a Go-Kart vehicle in accordance with the international standards stated for go kart racings.[4][5][6] Go-kart is generally used for giving much more practice to formula one driver for getting small details of the tracks and other parameters considered while racing. We began the task of designing by making research of each main component of the vehicle. We considered each component to be significant, and thereby design of systems of the vehicle. We used the necessary parameters to create a Flow Process Chart (FPC) to determine which parameters were the most critical. These key parameters ranging from most critical to least critical are safety, low cost, reliability, ease of operation and maintenance and overall performance; along with design of various components to meet the set parameters we also used Design Failure Mode Effect Analyses (DFMEA) and Design Validation Plan Report (DVPR) techniques which helped us to improve various components and systems of our vehicle by implementing the suggestions received from techniques.*

**Keywords:** *Go-kart vehicle, racing vehicle, Finite Element Analysis, Roll Cage*

### I. INTRODUCTION

Go-Kart is a racing vehicle having very low ground clearance and can be work on only flat racing circuits. The design process of this single-person go-kart is iterative and based on several engineering processes.[5]The designing work is done to achieve the best standardized as well as optimized design possible to meet international standards. Besides performance, consumer needs of serviceability, endurance ability and affordability were also kept in concern which we got to know through the market and internet research and reviews for go-kart vehicles. There is no suspension system provided for go-kart so it becomes very complicated to design such a flexible chassis which can be work for suspension during the turns.[5]After the primary specifications were set 3-D software model is prepared in solid works software. After the solid modeling the design is tested against all types of failure by conducting various simulations and stress analysis in Ansys Software. Based on the result obtained from these tests the design is modified accordingly.

**II. DESIGN CONSIDERATIONS**

To design and fabricate high performance racing vehicle which will be safe by ergonomically, economically and by all means safety considerations following main parameters were set before the designing; on which whole design process is carried out, [5]

- I. Driver Ergonomics.
- II. Serviceability and maintainability.
- III. Maneuverability.
- IV. Design of flexible roll cage.
- V. Use of optimum power efficiency.
- VI. Cost of the components.

To meet all above considerations and for ease in designing; all systems were designed individually along with mutual specifications considerations for interchangeability. [6]

- I. Roll Cage
- II. Steering System
- III. Braking System
- IV. Powertrain System

**2.1. Roll Cage**



**Fig.1Design Methodology of Roll Cage**

Roll Cage is askeleton of any vehicle which is used to provide support and mounting points for primary and secondary systems of vehicles. [1]For go kart the main consideration in design of roll cage is that due to no suspension it should have flexibility which will be act as suspension while in motion. For that the cross section of material chosen is of pipe cross-section which will have high strength with flexibility also [5]; so from survey we got 3 materials as per the requirements which are AISI 1018, AISI 1022 and AISI 4130. Every material having own specifications and properties which are making it proper to use but we chose AISI 1018 as having good strength with flexible in nature against the load.

↓ Properties	Material →	AISI 1018	AISI 1022	AISI4130
Modulus of Elasticity (Gpa)		205	200	210
Caron Content %		0.15-20	0.20-23	0.28-33
Yield Strength (Mpa)		370	375	435
Ultimate Strength (Mpa)		440	400	560
Density (kg/m <sup>3</sup> )		7.87x10 <sup>3</sup>	7.70x10 <sup>3</sup>	7.85x10 <sup>3</sup>

**Fig.2 Material comparison for Roll Cage material**

Outer Diameter of pipe cross section: 25.4 mm (1 Inch)

Thickness: 1.8 mm

After selection of material next step is to draw 3-D model of roll cage with all considering set parameters of various systems and sub systems.

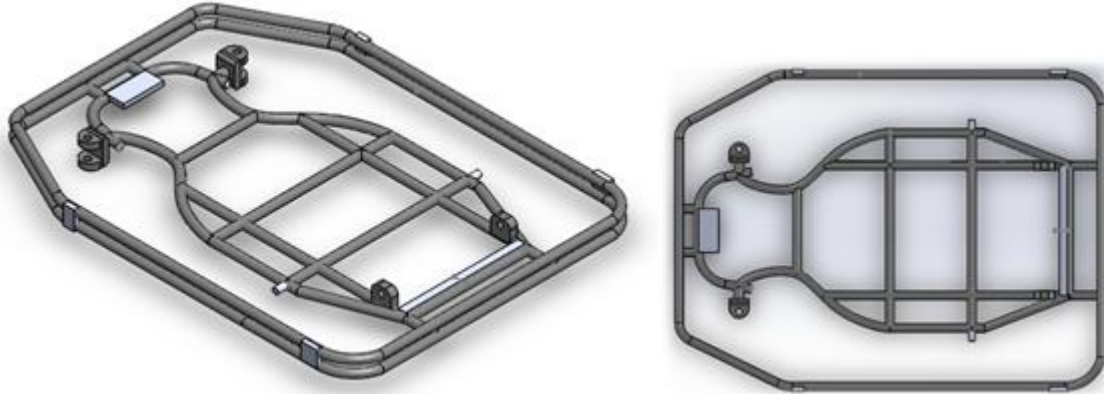

**Fig.3 Roll Cage 3-D model (Isometric view and Top view)**

**2.1.1 FEA Analysis Roll Cage model in ANSYS Software**

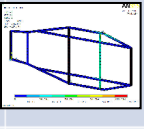
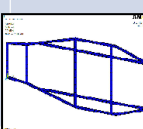
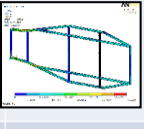
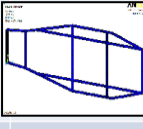
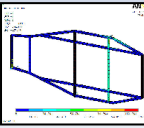
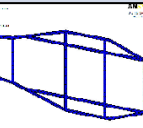
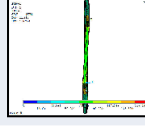
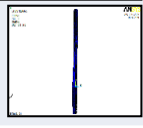
Impact	Impact Force (N)	Stress (N/Mm <sup>2</sup> )	Deformation (Mm)	F.O.S	Torsion Stiffness (N/mm)	Stress Analysis	Deformation Analysis
FRONT IMPACT	4414.5 (6G)	72.314	0.2464	2.90	3344.19		
REAR IMPACT	4415.5 (6G)	71.296	0.22116	2.94	2508.14		
SIDE IMPACT	2943 (6G)	127.35	0.4350	1.64	2229.46		
TORSION IMPACT	834 (2G)	176	11.664	1.20	6300.12 Tensional Rigidity = 4786.56		

**Fig.4 FEA Analysis Roll Cage in ANSYS**

**2.2. Steering System**



**Fig.5 Design Methodology of steering system**

There are many types of steering systems and mechanisms are there in various automobile vehicles; but they having low response timing. [2] For go-kart which is used for racing vehicle have to be equipped with quick

response and actuating steering system for that the steering system used in this vehicle is newly designed and modified from many systems i.e. reverse pitman arm steering. [6] Unlike other systems it having steering rods connected to a single disc which is directly welded to the steering rod for zero lagging and quick response. [6]

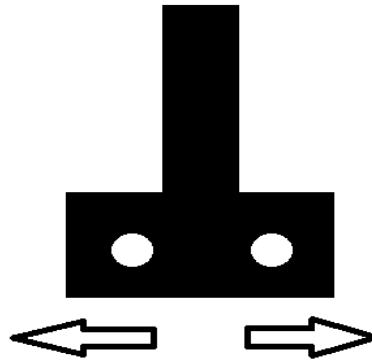

Fig.6 Pitman steering arm

Parameters	Values
Wheel track	42"
Wheel Base	48"
Camber angle	-3 <sup>0</sup>
Tie rod length	10 <sup>0</sup>
Steering ratio	13.119:1
Movement ratio	6.28:1
Torque at steering arm	45 N-m

Calculations	Output Values
Steering wheel rotation	1.3 (168 <sup>0</sup> )
Inner turning radius	2.227 m
Outer turning radius	2.333 m
Maximum inner turning angle	35 <sup>0</sup>
Maximum outer turning angle	23.47 <sup>0</sup>

Fig.7 steering system calculations

### 2.3. Braking System



Fig.8 Design methodology of braking system

Brake is an important part of any vehicle as brakes are used to stop the vehicle. To bring the vehicle in motion to the rest position brakes are used as per international standards for go-kart only hydraulic disc brake is to be apply. Go-kart having single rear axle which is used to transmit the power from engine to the wheel disc brake is directly mounted on the axle so that when the brakes are applied brakes will be applied immediately and vehicle will come to rest position in less time and in less distance.[6] But as there are some components of brake system are not possible to manufacture the are directly taken as Original Equipment Manufacturer (OEM) like Disc, Calipers, Master cylinder and fluid lines as stated in following table.[3]

Part	OEM	Value
Disc	Maruti 800	200 mm dia.
Caliper	Maruti 800	29 mm dia.
Master Cylinder	Maruti 800	25.4 mm dia.



Fig.9OEM Selected Fig.10single braking system

$$F \propto \frac{r}{R} \times 2 \times \mu \times \frac{A_w}{A_m} \times (Rp \times f)$$

Fig.11 Total force formula to find out force required [2]

Parameter	Value
Pedal ratio	6:1
Driver efforts	225 N
Brake force on TMC	1350 N
Pressure inside TMC	3.21 Mpa
Caliper force	4247.48 N
Total clamping force	8494.96 N
Frictional force (Pad & Disc)	3397.98 N
Braking torque	271.83 N-m
Deceleration	0.7 g
Static Load Distribution	45 : 65
C.G. position	X= 36” Y=18” Z= 3“

Velocity (km/hr)	40	50	60	70	80
Stopping distance (m)	13.41	19.21	26.01	33.77	42.56
Deceleration (m/s <sup>2</sup> )	4.60	5.014	5.335	5.595	5.800
Stopping time (Seconds)	2.41	2.76	3.12	3.47	3.83

Fig.12 Output parameters of braking system

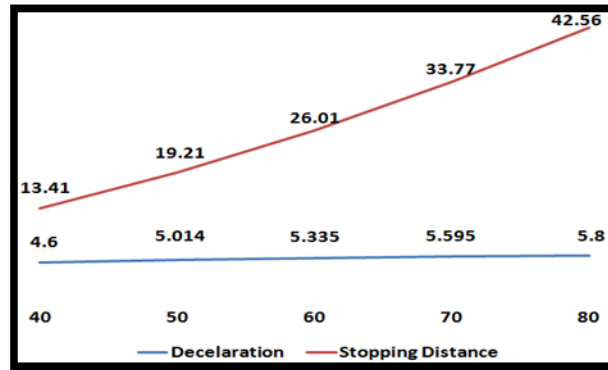

Fig.13 Deceleration and Stopping distance vs. Speed of vehicle

As shown in above graph of deceleration, stopping distance vs. speed of vehicle as the speed of vehicle increases deceleration increases considerably also stopping distance is increasing respectively. This indicates that stopping distance and decelerations are in directly proportion of the speed of vehicle.

2.4. Power Train Arrangement

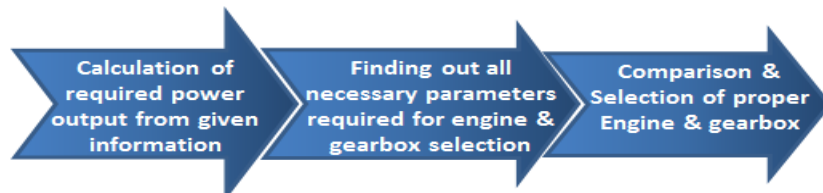

Fig.14 Design methodology of powertrain system

As per the international standards go-kart is generally equipped with 125 cc engine; and for ease of driver operations and power transmission we have to select automatic transmission of powertrain. [4] So we done market survey on our requirement basis and we got three results matching to our search from which to get maximum power and low cost we selected the engine of SUZUKI Access 125 for our use. Following table shows the comparison of the various engines.

	Honda Activa 125	Suzuki Access 125	Mahindra Rodeo 125
Engine	129.4cc	124cc	124.6cc
Power (hp)	8.6@6500rpm	8.58@7000rpm	8.04@7000rpm
Torque (Nm)	10.12@5500rpm	9.8@5500rpm	9@5500rpm
Price	50000	20000	30000
Availability	Less	More	More

Fig.15 Comparison of various engines available as per requirement



Fig.16 Engine of SUZUKI Access 125

Displacement: 124cc  
 Max. Power: 8.7 bhp  
 Engine description: 4 strokes  
 No. of Cylinders: Single cylinder  
 Cooling: Air cooled  
 Bore: 53.5 mm  
 Stroke: 55.5 mm

Fig.17 Engine specifications

Primary gear reduction ratio	Secondary gear reduction ratio	Final gear reduction ratio
3.000	1.045	2.2
Primary Torque	Secondary Torque	Final Torque
29.4 N.m	10.241 N.m	5.24 N.m
Primary speed	Secondary speed	Final Speed
8.956 Km/hr	35.99 Km/hr	78.25 Km/hr

Fig.18 Power output of engine to wheel

So to get speed of 80 km/hr final gear reduction ratio of 2.2 is used. And also torque for starting and final has been calculated as above.

### III. CONCLUSION

There are several factors to be considered that are common to all engineering vehicles. With an approach of engineers can come up with the best possible product for the society. The chosen design is the safest & the most reliable car for any racing vehicle. All the parameters like Reliability, safety, Cost, Performance, aesthetics, ergonomics, Standard dimensions & material were also taken in consideration on the same time.[5] Where ever possible finite element analysis was done on the regularly loaded parts & modifications were done accordingly to avoid any type of design failure. Also while designing every individual part DFMEA and DVPR has been done which improved our quality standard, factor of safety and other safety parameters also.

The designed go-kart is able to withstand against any adverse condition on road as each component is designed specifically considering all types of failures and safety issues; it is the best vehicle for racing on circuit.as there is no suspension used in kart roll cage id designed in such a way that it having maximum flexibility in slight twisting motion to accommodate the role of suspension while turning and other twisting motions.[5] Also powertrain is specially designed to get maximum speed and torque for high performance which can be given by

the any other geared vehicle. It becomes plus point of vehicle that it having automatic gear system with high speed output. For designing this vehicle many software's like solid works, Catia, Ansys were used to get more clear and accurate output of designed parameters to meet high accuracy and to reduce any type of any unlike situation.

#### **4. REFERENCES**

- [1] Milliken & Milliken, "Race Car Vehicle Dynamics"
- [2] James D. Halderman, "Automotive Technology" 4<sup>th</sup> edition
- [3] Reza M. jazar, "Vehicle Dynamics Theory and Applications(BBS)"
- [4] "Go-Kart Manufacturers and specifications ", [www.wikipedia.com](http://www.wikipedia.com)
- [5] "how to design go-kart" [www.instructables.com](http://www.instructables.com)
- [6] "how to build a kart" [www.kartbuilding.net](http://www.kartbuilding.net)