

# FIBER CABLE FAULT MANAGEMENT SYSTEM

**Sanjeev Kumar<sup>1</sup>, Prof. Y C Bhatt<sup>2</sup>**

<sup>1</sup> *Asst. Professor, AIACT&R, Delhi (India)*

<sup>2</sup> *Director JNIT, Jaipur (India)*

## ABSTRACT

*The cabling of fiber optics early adopters has been deployed and in operation for more than 30 years, a testament to the distinct advantages of optical fiber. Over this period of time, copper cabling has been through multiple generations but optical fiber cables have many distinct advantages over copper cables. But according to the Federal Communications Commission reports, more than one fourth of service disruption is attributable to fiber cable problems. Preventing these fiber related service problems has become a top priority. When making the decision on purchasing your cable management system, the goal is getting the most cost-effective system that provides the best cable management, flexibility, and growth capabilities. Going with the cheapest approaches can cost more money in the long run. A strong fiber cable management system will enable you to extract the maximum value from your installed optical fiber networks. In this paper three types of fiber cable management systems are discussed and compared.*

**Keywords:** *Optical Networks, SDH, ADM, OTDR, PCM*

## I INTRODUCTION

The optical fiber cable networking is widely in use in the world because of its bandwidth and cost. Because of advanced manufacturing techniques the fiber cable is easy to produce and therefore the network of the fiber cable is increasing day by day. With such a high bandwidth the fiber cable networking is cheaper than other metallic cables. Fiber cables have low losses therefore it can be used for longer distances as compared to the metallic cables. The use of fiber cable is increasing and technology like fiber to the home is coming in practice. Fiber cable is the better option for high speed internet surfing and television system. Fiber to the home is a good option for these applications. The fiber cables are also being used as high bandwidth trunks from one exchange to another exchange. The different signals get multiplexed from one exchange and can be transmitted with high bandwidth through the fiber cables at a longer distance than the other cables. But the network fault management is very important. When a failure occurs in the network without being detected or the failure cannot be localized exactly, it will lead to network's inability to start the normal protection/restoration mechanism. Hence, fault detection and location is a direct impact on optical networks. Fault location problem in networks have been difficult to deal with, because when network failures happen, all related nodes will report alarms. When many alarms reach the main exchange through the management communication network, it becomes difficult to locate the multi failures exactly without much troublesome manual checking and measuring.

### 1.1 SDH Network Elements

- SDH Regenerator
- Line Terminal Mux (LTM)
- Add Drop Mux (ADM)

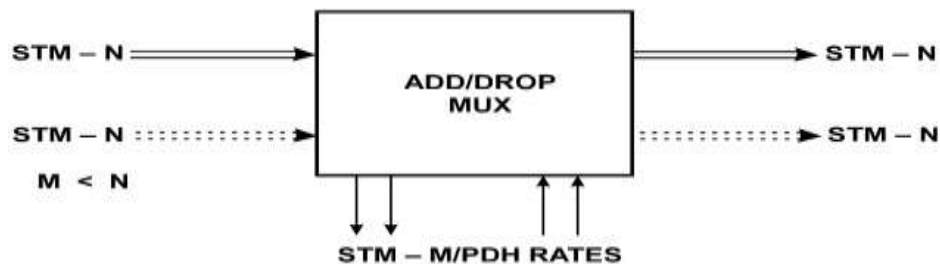

Having introduced you to the concept of an SDH Network, let's now take a look at the network "building blocks" and how they are configured. These network elements are now all defined in CCITT standards and provide multiplexing or switching functions.

Line Terminal Multiplexers – can accept a number of tributary signals and multiplex them to the appropriate optical SDH at carrier, i.e. STM-1, STM-4 or STM-16. The input tributaries can either be existing PDH signals such as 2, 34 and 140 Mb/s or lower rate SDH signals. LTMs form the main gateway from the PDH network to the SDH.

Add-drop Multiplexers – a particular type of multiplexer designed to operate in a through mode fashion. Within the ADM, it is possible to add channels to, or drop channels from the "through" signal. ADMs are generally available at the STM-1 and STM-4 interface rates and signals, i.e. 2, 34 or 134 Mb/s. The ADM function is one of the major advantages resulting from the SDH since the similar function within a PDH network, required banks of hardwired back-back terminals.

Synchronous DXC – these devices will form the cornerstone of the new synchronous digital hierarchy. They can function as semi-permanent switches for transmission channels and can switch at any level from 64 kb/s up to STM-1. Generally, such devices have interfaces at STM-1 or STM-4. The DXC can be rapidly reconfigured under software control, to provide digital leased lines and other services of varying bandwidth.

## II TRANSPORT OF ASYNCHRONOUS 2048 KBPS TRIBUTARIES ON STM-1 FRAME

STM-1 frame can provide transport of 140 Mbps, 34 Mbps and 2048 Kbps tributaries. In this handout, we discuss mapping of asynchronous 2048 Kbps tributaries on STM-1 frame. Asynchronous here implies that the clocks of the tributaries are not synchronized to the clock of the SDH system.

### 2.1 Alternatives for Mapping 2048 Kbps Tributary on STM-1 Frame

There are two alternatives for transporting 2048 Kbps tributary on STM-1 frame. The first alternative is via VC-4 and the second is via VC-3 as shown in Figure.

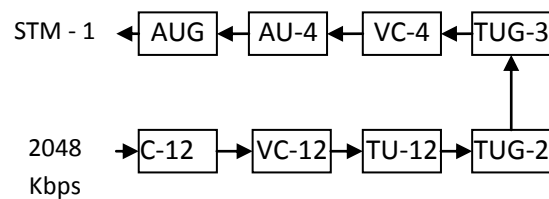

In this handout, we will describe the processes enclosed within dotted lines. Note that up to TUG–2 the processes are common for both the alternatives.

## 2.2 Asynchronous Mapping of 2048 Kbps Tributary into VC–12

One 2048 Kbps tributary can be mapped into a VC–12. Steps involved. C–12 container is formed first by inserting justification and fixed stuff bytes. Justification makes the information bit stream bit and byte synchronous to the SDH environment.

### Types of faults in fibre cable:

1. Fibre Break
2. Fibre loss
3. Faults in OLT cards
4. Connector faults

### How to find the faults and their removal

1. With OTDR and Splicing: Sometimes fibre break occurs and the break can be identified with the use of OTDR. To remove these types of faults splicing is done.
2. Power meter and change fibre: During maintenance the Rx and Tx fibre may change. This type of fault can be solved with the help of Power meter.
3. Power meter and change OLT card: Sometimes OLT card may be faulty. This can be find out with the help of power meter. Then in this case we have to change OLT card.
4. Power meter and change the connector: If the connector is faulty then replace it with another connector. This can be done with the help of Power Meter.

## III EXPERIMENTAL SET UP

In this experiment the ring topology is used in an optical network. There are four stations as shown in the diagram and at each station there is one are STM-1 ADM. At the main station all 63 PCMs dropped. These dropped PCMs are connected to the higher level of STM system. But all 63 PCMs are not in working condition. Some of the PCMs can be used for the maintenance purpose. The remaining three sub stations can add or drop maximum of 63 PCMs. In this experiment 15 PCMs have been dropped at each substation. Therefore total 60 PCMs are in use. Each ADM is configured as per the requirement of the station. In an add/drop multiplexers (ADM) lower bit rate synchronous signals can be extracted from or inserted into high speed SDH bit streams by

means of ADMs. This feature makes it possible to set up ring structures, which have the advantage that automatic back-up path switching is possible using elements in the ring in the event of a fault.

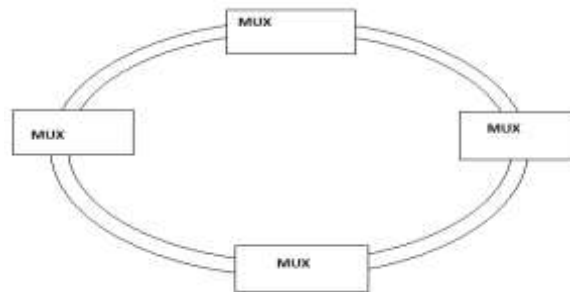

In this network structure, connections between network elements are bi-directional. The overall capacity of the network can be split up for several paths each with one bi-directional working line, while for unidirectional rings, an entire virtual ring is required for each path. If a fault occurs between neighbouring elements A and B, network element B triggers protection switching and controls network element A by means of the K1 and K2 bytes in the SOH.

Even greater protection is provided by bi-directional rings with 4 fibres. Each pair of fibres transports working and protection channels. This results in 1:1 protection, i.e. 100 % redundancy. This improved protection is coupled with relatively high costs.

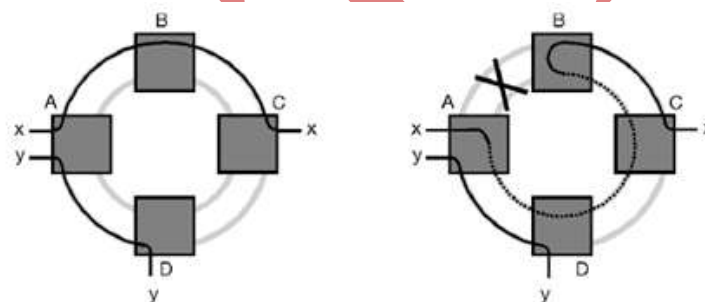

There are three methods of the fibre cable fault management have been studied.

**3.1 First Case (A1):** All the SDH network elements mentioned so far are software-controlled. This means that they can be monitored and remotely controlled, one of the most important features of SDH. The Network Management System interface (NMS Interface) provides a CSMA/CD based LAN transceiver of an Ethernet link. This is available as an RJ-45 connector on the PXAT. The Ethernet address is available in the non-volatile memory on the PXAT. The NMS interface physical layer is completely implemented in hardware. The physical layer device provides clock recovery, bit timing, equalization and a 'Jabber' circuit. The Media Access Control (MAC) function is implemented in software available as part of the microcontroller. 'Jabber' circuitry ensures that the transmitter does not hold up the interface for more than a full frame of data. Two LEDs are used to indicate link status of the connector.

The following diagram shows IP addresses given to the nodes

The status of the fibre can be known from the system by logging each ADM. The above diagram shows that first the Laptop or PC is set with some IP addresses and then only system login is possible. Once we know about the fault in fibre cable then we should use OTDR or power meter to find location/nature of the fault.

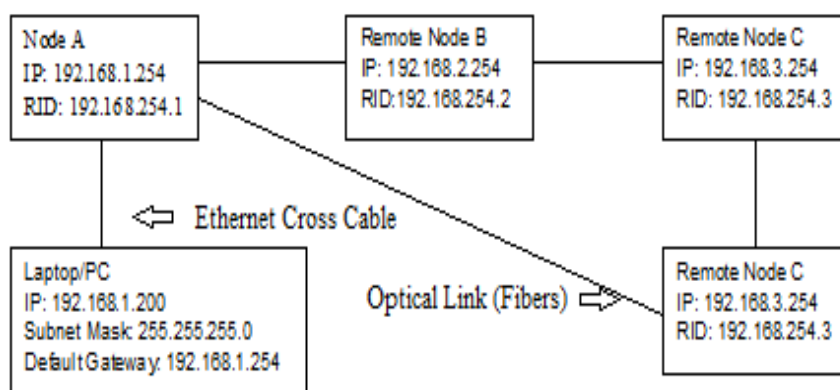

**3.2 Second Case(A2):** The first method used for the faults is very troublesome and time taking because we have to login each system one by one and if there are a number of systems then it will take long time to find faults. The second method used for the fault finding is software based. In This method we can see several system's faults at a time. This method requires skilled resource person and extra cost. System software gives the information about the faults in various fibre cables and the location /nature of the fault can be known by the use of OTDR/Power Meter. The following graph shows the distance for a particular fibre with the help of OTDR.



**3.3 Third Case(A3) :** The above methods are lengthy and require skilled resource person. This proposed method is very quick and no any skilled person is required to operate this. This method requires some extra configuration of systems which are being used in the optical ring networks. A device is also required which can show the near end loss and far end loss of the PCM's. This device takes input as PCM and indicates loss with the help of LEDs. When there is alarm indicated by near end loss LED, the fault is in local area. This indication of loss is not concerned with fibre cable losses. But when there is alarm of far end, it means there is fibre cable fault near the station (the concerned PCM dropped at the station). The following diagram shows the ring

network working with the convertor connections. If there are four stations then four convertors are required. The convertor must have loss indicative LEDs equal to the number of substations in the network.

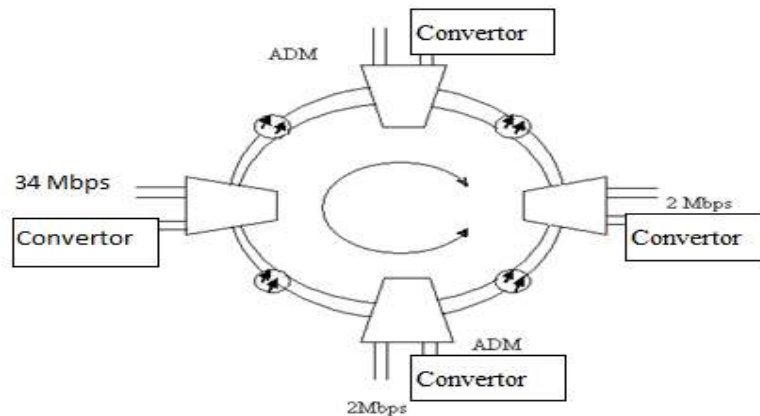

This purposed method is very convenient for the maintenance engineer. As he entered in the office he can see convertor to check the fibre cable faults. When the convertor shows the far end loss of particular station the fault location can be measured with help of OTDR and the action can be taken immediately. The following graph shows the distance for a particular fibre with the help of OTDR.

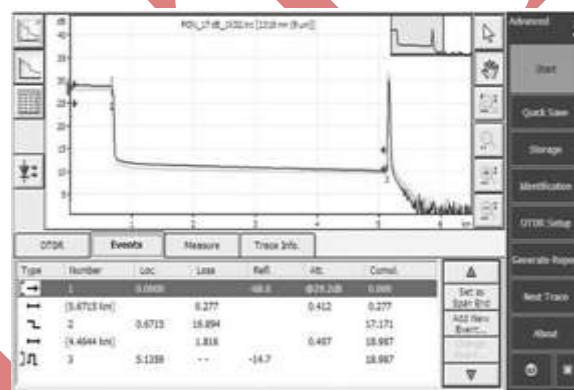

**Comparison of the methods:** Three methods have been discussed above and comparison can done easily. The following graph shows the comparison of methods.

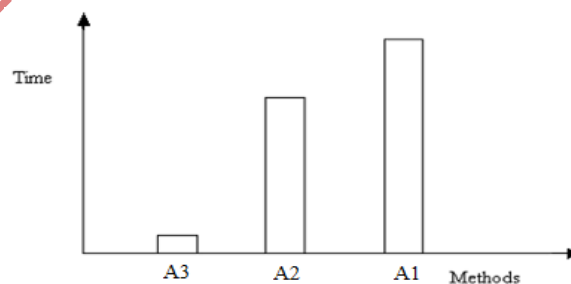

The following table explains the detailed comparison of the methods.

Parameters	Case A1	Case A2	Case A3
------------	---------	---------	---------

Time	Highest	Higher	Very Low
Complexity	Highest	Higher	Low
Maintenance	Not Required	Not Required	Low
Easy to use	Difficult	Difficult	Very Easy
Probability of Error	Very Low	Very Low	Very Low
Cost	No Extra Cost	Highest	Low
Skill required	Skilled	Skilled	Not Required

#### IV CONCLUSION

The third method discussed above is best method for fibre cable networks. This method is cheap and accurate. The optical networking is increasing day by day. Therefore an efficient fibre cable fault detection system is compulsory. The vulnerabilities of fundamental optical network physical components, and the associated attack techniques, demand for new, tailored attack detection, localization and network restoration techniques. It is required to upgrade existing ways of dealing with optical fibre cable network failures and attacks and significant attention should be paid to prevention mechanisms taking physical-layer vulnerabilities into consideration in the network planning. This approach, i.e., prevention oriented network planning, is a very new concept aimed at increasing SONET/SDH optical network security in an economically more viable way.

#### REFERENCES

- [1] M.S.A. Rahman and B.C. Ng, "MATLAB-based graphical user interface development for Centralized Failure Detection System (CFDS) in SCAN Network," *J. of Opt. Commun.*, vol. 29, no. 3, pp. 152-156, 2008.
- [2] C.H. Lee, W.V. Sorin and B.Y. Kim, "Fiber to the home using a PON infrastructure", *Journal of Lightwave Technology*, Vol. 24, No. 12, pp. 4568- 4583, 2006.
- [3] M.S.A. Rahman, A.A. Ehsan and S. Shaari, "Survivability in FTTH PON access network using optical cross add and drop multiplexer switch", *Journal of Optical Communication, JOC (German)*, Vol. 27, No. 5, pp. 263-269, 2006.
- [4] Telcordia GR-253-CORE, Synchronous Optical Network (SONET) Transport Systems: Common Generic Criteria (October 2009). Issue 5.
- [5] Ramamurthy S, Mukherjee B. A review of fault management in WDM mesh networks: basic concepts and research challenges. *IEEE Network* 2004; 18(2)
- [6] Ramamurthy S, Sahasrabudde L, Mukherjee B. Survivable WDM mesh networks. *Journal of Lightwave Technology* 2003; 21(4): 870–883.
- [7] B. Chomycz, *Fiber optic installation: a practical guide*, McGraw-Hill, New York, USA, 1996.
- [8] B.A. Forouzan, *Data communications and networking*, 4th ed., McGraw-Hill, New York, USA, 2007.

- [9] EXFO, *FTB-7000 optical time domain reflectometer series ToolBox 5 instruction manual*, 7th ed., EXFO Electro-Optical Engineering Inc, Canada, 2000.
- [10] Mohammad Syuhaimi Ab-Rahman and Boonchuan Ng “Graphical User Interface Capabilities of MATLAB in Centralized Failure Detection System (CFDS)” *International Journal of Microwave and Optical Technology* Vol. 4 No.2, March2009.

UNACCEPTED